



MHP SERIES

MOBILE HYDRAULIC PULVERIZER

CE Operating and
Maintenance Manual



CE

Part Number 514990
1/2018 Ver. 4

CONTACT INFORMATION

MAIN OFFICE ADDRESS

LaBounty, 1538 Highway 2, Two Harbors, MN 55616; Phone: 218-834-2123 - 800-522-5059; Fax: 218-834-3879
Stanley Infrastructure, 3810 S.E. Naef Road, Milwaukie, OR 97267; Phone: 503-659-5660; Fax: 503-652-1780
www.stanleyinfrastructure.com

MOUNTED ATTACHMENTS - NORTH AMERICA REGIONAL MANAGERS

John Portwood - North American Sales Manager - Mounted Attachments
Cell: 303-513-7595 | John.Portwood@sbdinc.com

Randall Carmona - Northwest Regional Sales Manager
Cell: 503-209-7943 | Fax: 503-786-5177 | Randall.Carmona@sbdinc.com

Greg Goerke - Great Lakes Regional Sales Manager
Cell: 716-450-9465 | Fax: 716-488-2945 | Gregory.Goerke@sbdinc.com

Scot Stein - South Central Regional Sales Manager
Cell: 512-569-7503 | Scot.Stein@sbdinc.com

Rob Murray - Midwest Regional Sales Manager
Cell: 218-393-0979 | Rob.Murray@sbdinc.com

Bob Stuppy - Western Regional Sales Manager
Cell: 909-224-9304 | Fax: 866-716-9286 | Bob.Stuppy@sbdinc.com

Larry Gilberson - Northeast Regional Sales Manager
Cell: 609-836-3471 | Larry.Gilberson@sbdinc.com

Dave Reed - Southeast Regional Sales Manager
Cell: 410-937-5304 | Dave.Reed@sbdinc.com

INTERNATIONAL ACCOUNT MANAGERS

Christophe Jarrin - European Commercial Leader | Europe
Phone: (+33) 667 0535 24 | Christophe.Jarrin@sbdinc.com

Dmitry Sosin - Sales Manager Russia CIS Baltic States, Poland, Scandinavia
LaBounty: (+7) 91 1819 03 48 | Dmitry.Sosin@sbdinc.com

Kenan Cirak - Regional Sales Manager Europe
Cell: (+49) 173 510 5381 | Kenan.Cirak@sbdinc.com

Alex Kim - Sales Manger Asia
Cell: (+82) 10 3230 9119 | Alex.Kim@sbdinc.com

Alejandro Maero - Regional Sales Manager South America
Cell: (+54) 9 3571 572043 | Fax: (+54) 3571 472045 | Alejandro.Maero@sbdinc.com

Flavia Garcia - Latin America Sales Manager
Cell: (+55) 11 966359033 | Phone: (+55) 11 31497475 | Flavia.Garcia@sbdinc.com
2 MHP Operating & Maintenance Manual



CONTACT INFORMATION

CUSTOMER SERVICE - LABOUNTY

INSIDE SALES AND SERVICE

Greg Connor - Inside Sales & Service Manager
Phone: 218-834-6722 | Greg.Connor@sbdinc.com

Mike Dahlgren - Inside Product Support
Phone: 218-834-6715 | Mike.Dahlgren@sbdinc.com

Garry Wood - Inside Product Support
Phone: 218-834-6840 | Garry.Wood@sbdinc.com

Jen Kunkel - Inside International Sales Rep. and Parts Manager
Cell: 218-834-6803 | Phone: 800-522-5059 | Jennifer.Kunkel@sbdinc.com

NORTH AMERICA FIELD SUPPORT & SERVICE

Brian Hawn - Field Technical Manager
Cell: 217-621-5596 | Brian.Hawn@sbdinc.com

Brice Paillet - Field Service Supervisor - Europe
Cell: 00 33 6 28 51 17 88 | Brice.Paillet@sbdinc.com

John Coale - Northeast Region
Cell: 410-776-4099 | Phone: 410-808-3956 | Fax: 866-644-5758 | John.Coale@sbdinc.com

Brett Williams - South Central Region
Cell: 817-681-6691 | Phone: 218-834-6700 | Fax: 877-370-9504 | Brett.Williams@sbdinc.com

Bobby Oldham - Southeast Region
Cell: 678-850-7923 | Bobby.Oldham@sbdinc.com

Kevin Robinson - Western Region
Cell: 951-388-9501 | Kevin.Robinson@sbdinc.com

Mike Nelson - North Central Region
Cell: 218-220-0409 | Mike.Nelson@sbdinc.com



NORTH AMERICAN SERVICE COVERAGE MAP

LaBounty Sales Territory Map North America

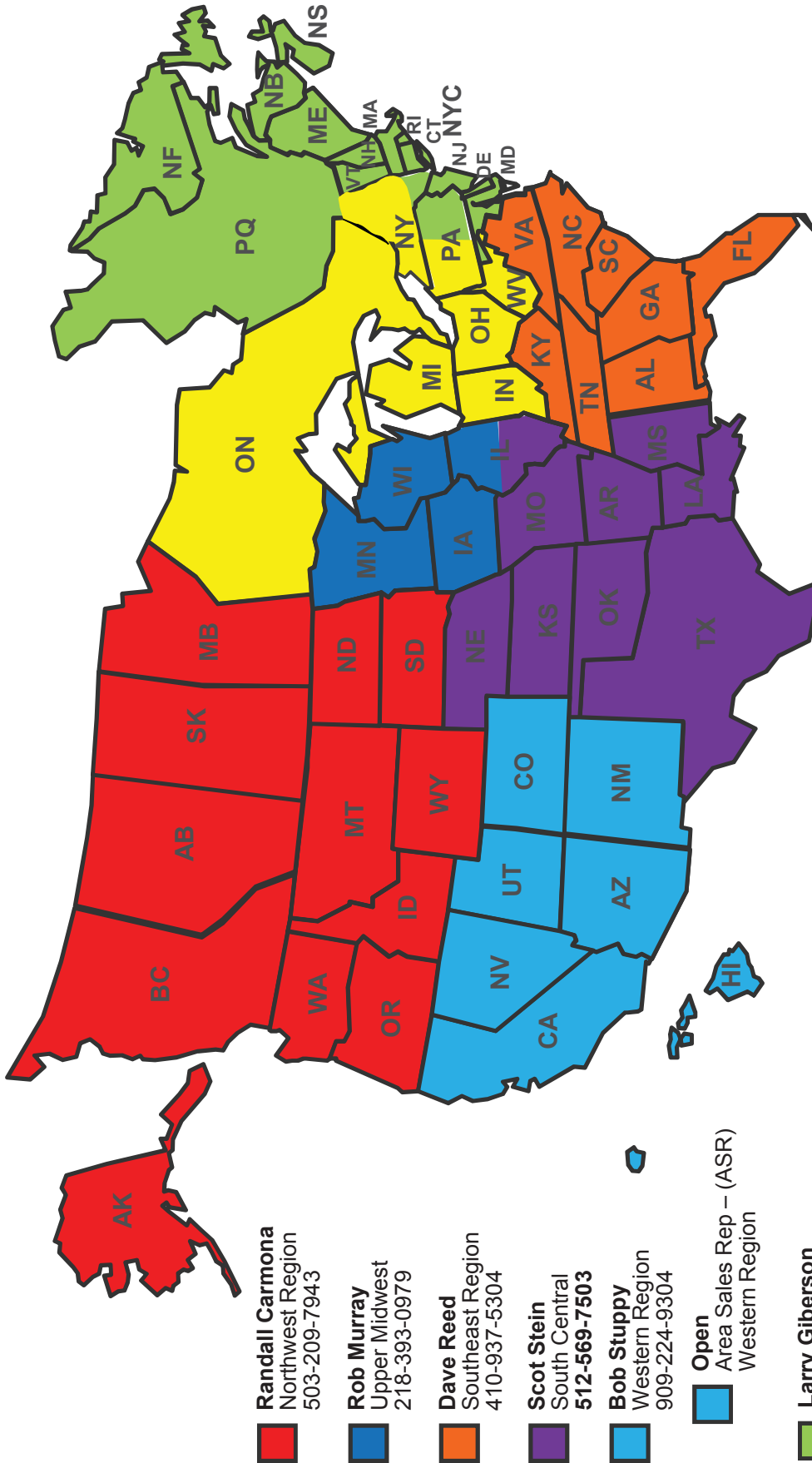

- Randall Carmona**
Northwest Region
503-209-7943
- Rob Murray**
Upper Midwest
218-393-0979
- Dave Reed**
Southeast Region
410-937-5304
- Scot Stein**
South Central
512-569-7503
- Bob Stuppy**
Western Region
909-224-9304
- Open**
Area Sales Rep – (ASR)
Western Region
- Larry Giberson**
Northeast
609-836-3471
- Greg Goerke**
Great Lakes
716-450-9465

John Portwood
LaBounty Sales Manager – North America
303-513-7595

11.20.2017



PREFACE

This manual contains information for the safe and proper operation and maintenance of the LaBounty MHP Mobile Hydraulic Pulverizer. Read the entire manual before the initial start-up of the attachment. It is important to know the correct operating procedures of the attachment and all safety precautions to prevent the possibility of property damage and personal injury.

The LaBounty attachment has been designed and manufactured with high quality materials and care in workmanship. The instructions in this manual have been prepared to ensure that, when followed properly, the attachment will provide efficient and reliable service. Continuing product development and improvement may have caused changes in the attachment that are not reflected in this manual. If a question arises regarding the operation or maintenance of the attachment, contact a LaBounty dealer for the most current information available.

IMPORTANT

This operator's manual must accompany the attachment at all times and be readily available to the operator.

MANUAL REPLACEMENT

Should this manual become damaged, lost or additional copies are required, immediately contact any authorized LaBounty dealer. You may also download a PDF copy at www.stanleyinfrastructure.com.

REGISTRATION FORM

The Warranty Registration Form must be filled out by the dealer or customer and returned to LaBounty indicating the date the machine went into service.

POSSIBLE VARIATIONS

LaBounty cannot anticipate every possible circumstance that might involve a potential hazard, as the owner's requirements and equipment may vary. Therefore, the warnings in this publication and on the product may not be all-inclusive and you must ensure that the procedure, application, work method and operating technique is safe for you, and others, before operation.

PUBLIC NOTICE

LaBounty reserves the right to make changes and improvements to its products and technical literature, at any time, without public notice or obligation. LaBounty also reserves the right to discontinue manufacturing any product at its discretion, at any time.

WARRANTY

All work or repairs to be considered for warranty reimbursement must be authorized by the LaBounty Service Department before work is started. Any alterations, modifications or repairs performed before authorization by the LaBounty Service Department will render all warranty reimbursement consideration null and void without exception. Improper operation or improperly performed maintenance may render any warranty null and void.



TABLE OF CONTENTS

Safety	7
Operational Safety	8
Decals & Terms	10
Installation	11
Third Member Installation.....	11
Hydraulic Installation	12
Operation	13
Technical Specifications	14
Attachment Controls.....	14
Bleed the Hydraulic Cylinder.....	15
Operating Tips.....	15
Swift-Lock Teeth Maintenance	17
Lubrication.....	18
Inspect / Torque Bolts.....	19
Main Pivot Group Maintenance.....	19
Blade Maintenance	20
Build Up & Wear Plates.....	21
Checking and Replacing Wear Plates.....	21
Hydraulic Maintenance.....	22
MHP Hydraulic Schematic	23
Troubleshooting	24

SAFETY



This is the safety alert symbol. It is used to alert you to potential personal injury hazards. Obey all safety messages that follow this symbol to avoid possible injury or death.



DANGER

This safety alert and signal word indicates an imminently hazardous situation which, if not avoided, will result in death or serious injury.



WARNING

This safety alert and signal word indicates a potentially hazardous situation which, if not avoided, could result in death or serious injury.



CAUTION

This safety alert and signal word indicates a potentially hazardous situation which, if not avoided, could result in minor or moderate injury.



NOTICE

This signal word indicates a situation which, if not avoided, will result in damage to the equipment.

Always observe safety symbols. They are included for your safety and for the protection of the tool.



Your safety and the safety of others is a direct result of how you operate and maintain your equipment. Read and understand this manual and other safety information provided with the base machine and be sure that you understand all controls and operating instructions before attempting to operate this equipment. Failure to follow the safety precautions can result in personal injury, death or property damage.

Carefully read all safety messages in this manual and on your equipment safety decals. Keep safety decals in good condition. Replace missing or damaged safety decals.

Because LaBounty cannot foresee all hazardous circumstances, the precautions listed in this manual and on the equipment are not all-inclusive. If a procedure, method, tool or part is not specifically recommended by LaBounty, determine whether it is safe for you and others, and that the equipment will not be damaged or made unsafe as a result of your decision to implement it.

The basic rules are summarized in this section of the manual. They also appear throughout the manual along with additional specific rules for safety and operation.

OPERATIONAL SAFETY



DANGER

- If the attachment is not functioning properly, shut down the machine, follow proper lockout / tag out procedures and follow proper repair procedures.
- **NEVER** operate equipment without the original safety guards in place.
- Ensure that the cab is equipped with the proper safety guards for LaBounty applications. The cab **MUST** be equipped with an approved Falling Object Protection Structure (FOPS). The FOPS must meet the requirements of SAE standard J1356. A transparent, shatter-resistant shield covering the front of the cab, is also required. Contact your base machine equipment dealer or manufacturer for more information on the availability of FOPS. Lack of proper FOPS may result in injury or death.
- **NEVER** operate the excavator without a proper restraint (seat belt) system in place. Doing so can create loss of control or ejection from cab.
- **NEVER** operate the equipment while under the influence of drugs, alcohol or other substances that inhibit mental abilities or reaction time.
- **DO NOT** process material with the attachment over the operator's cab. Doing so will result in severe personal injury or death from falling debris.
- **DO NOT** attempt to process brittle materials, such as axles and railroad rail. **DO NOT** process any material in a position that may propel it toward the operator, other workers, buildings or equipment.
- Clear all persons and equipment from the area of operation and machine movement. **NEVER** move loads over people or equipment. When viewing the operation of the attachment, maintain a safe distance of at least 75 feet (23 meters).
- **NEVER** approach power lines with any part of the machine. Keep clear at a minimum of 15 feet (5 meters).
- **DO NOT** close the attachment on a structure and reverse the excavator in an attempt to pull down material.
- Avoid tipping. The attachment will alter the lift capacities of the base machine. **DO NOT** overload the excavator or serious injury could result. Lift capacities will vary if the base machine is not on level ground. Lifting incorrectly can cause severe injury or machine damage. Use the recommended excavator counterweight. Use short slings and lift the load only as high as necessary.
- Use of this tool on certain materials could generate dust potentially containing a variety of hazardous substances, such as, asbestos, silica or lead. Inhalation of dust containing these, or other hazardous substances could result in serious injury, cancer or death. Protect yourself and those around you. Research and understand the materials you are processing. Follow safety procedures and comply with all applicable national, state or provisional health and safety regulations relating to them. If appropriate, arrange for the safe disposal of the materials by a qualified person.



WARNING

- Disassembly of any pin-connected attachment can be hazardous. **NEVER** remove any pin unless the attachment is on the ground and blocked up. Serious injury or death could result. Metal chips or debris may fly when a connecting pin is struck. Use a brass drift when striking pins and always wear protective clothing and proper eye protection. Pins may fly when struck with force to drive them in or out. Always keep people clear when removing or installing pins.
- **DO NOT** allow riders on the machine. Riders are subject to serious injuries, such as being struck by foreign objects or being thrown off the machine. Riders also distract and obstruct the operator, resulting in the machine being operated in an

OPERATIONAL SAFETY

unsafe manner. **NEVER** use the attachment as a work platform or personnel carrier.

- **DO NOT** modify LaBounty equipment without factory authorization. This equipment is designed to do a specific job and alterations could result in injury.
- **ALWAYS** lower the boom to the ground before leaving the cab. If it is necessary to work on an attachment off the ground, securely support the machine and attachment. **DO NOT** support the machine on cinder blocks, hollow tiles or props that may crumble under continuous load. **DO NOT** rely on a cylinder to hold the attachment in the air. If a control is moved or hydraulic pressure is otherwise released, the attachment may drop. **DO NOT** work under a machine that is supported only by a jack.
- Hydraulic oil becomes hot during operation. **DO NOT** come in contact with hot hydraulic oil as it could cause severe burns. Wear adequate protective clothing and safety equipment.
- **DO NOT** tamper with hydraulic lines or components while they are pressurized. Escaping fluid under pressure can penetrate the skin, causing serious injury. Keep hands and body away from pinholes and nozzles which eject fluids under high pressure. Use a piece of cardboard to search for leaks. If **ANY** fluid is injected into the skin, seek immediate medical assistance.
- Keep clear of potential pinch points, including the moving upper jaw, cylinder connections, bucket linkages and other moving parts.

CAUTION

- **DO NOT** weld on any structural member unless specifically authorized by LaBounty.
- **ALWAYS** wear close-fitting clothing and safety equipment appropriate to the job. Safety equipment should be worn at all times when viewing, operating or maintaining the attachment. Safety equipment includes eye protection, hard hat, steel toe shoes, gloves, hearing protection and respirator.

DECALS & TERMS

MODEL DESCRIPTION

MHP series Mobile Hydraulic Pulverizers are designed for quiet, controlled demolition and recycling of concrete structures. MHP uses crushing teeth to efficiently separate rebar from concrete.

DECAL MAINTENANCE

Ensure safety decals are installed and visible. Keep decals clean and promptly replace decals that are damaged. Replacement decals are available through the LaBounty Service Department. Place replacement decals in the same position as the original decals.



CAB GUARD DECAL
P/N 503647
FIGURE 1

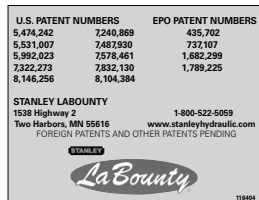

PATENT PLATE
P/N 116404
FIGURE 2

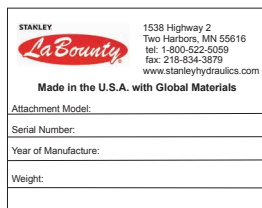

MODEL/SERIAL NUMBER PLATE
P/N 511045
FIGURE 3



SAFE DISTANCE DECAL
P/N 503706
FIGURE 4

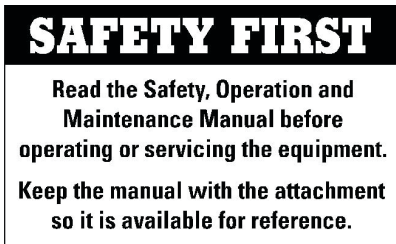

SAFETY FIRST DECAL
P/N 503590
(INCLUDED WITH MANUALS)
FIGURE 5

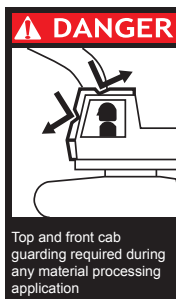

CAB GUARD DECAL
P/N 503647
FIGURE 7

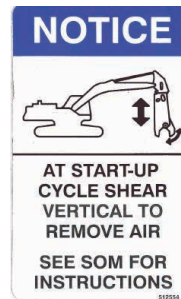

CYLINDER BLEED DECAL
P/N 512554
FIGURE 8

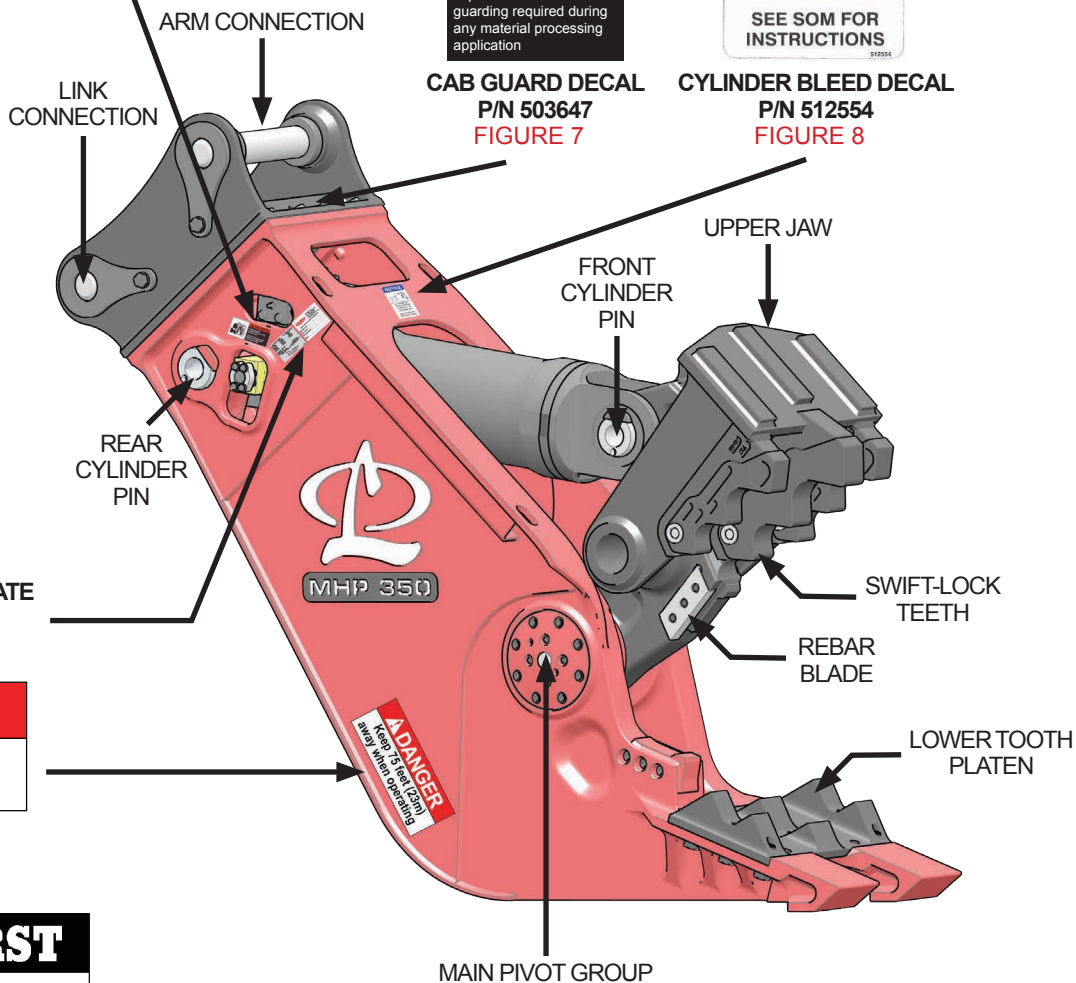

GREASE DECAL (AT EACH FITTING)
P/N 116388
FIGURE 6

INSTALLATION

⚠ WARNING

- Use only approved rigging hardware rated for loads greater than the weight of MHP.
 - Hooking Points are for moving the attachment only. Do not lift other objects or use MHP in a cable-hung application.
1. Locate flat, hard ground (e.g., concrete floor) for installation. Lift and place the attachment on the ground as shown. Use blocking if necessary.
 2. Remove the excavator bucket. Follow the manufacturer's recommended procedure.
Note: When removing the excavator bucket, plug hydraulic hoses to prevent contamination.

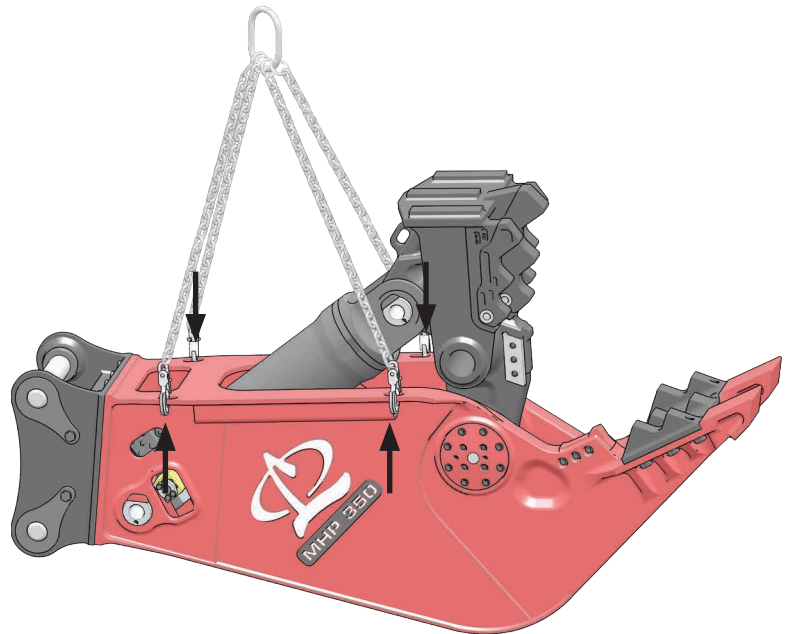

HOOKING POINTS FOR LIFTING
FIGURE 9

THIRD MEMBER INSTALLATION

3. Remove the arm connection and link connection pins, as shown in Figure 10.
4. Bring the excavator into position, carefully lining up the stick tip with the MHP mounting bracket. Pin the stick tip to the MHP mounting bracket using the pin provided (see Figure 11).
5. Carefully extend the bucket cylinder to move the bucket linkage. Position the link into the mounting bracket linkage connection.
Note: It may be necessary to use a lifting device (overhead hoist, forklift, etc.) to position the link.
6. Pin the linkage connection to the MHP bracket..

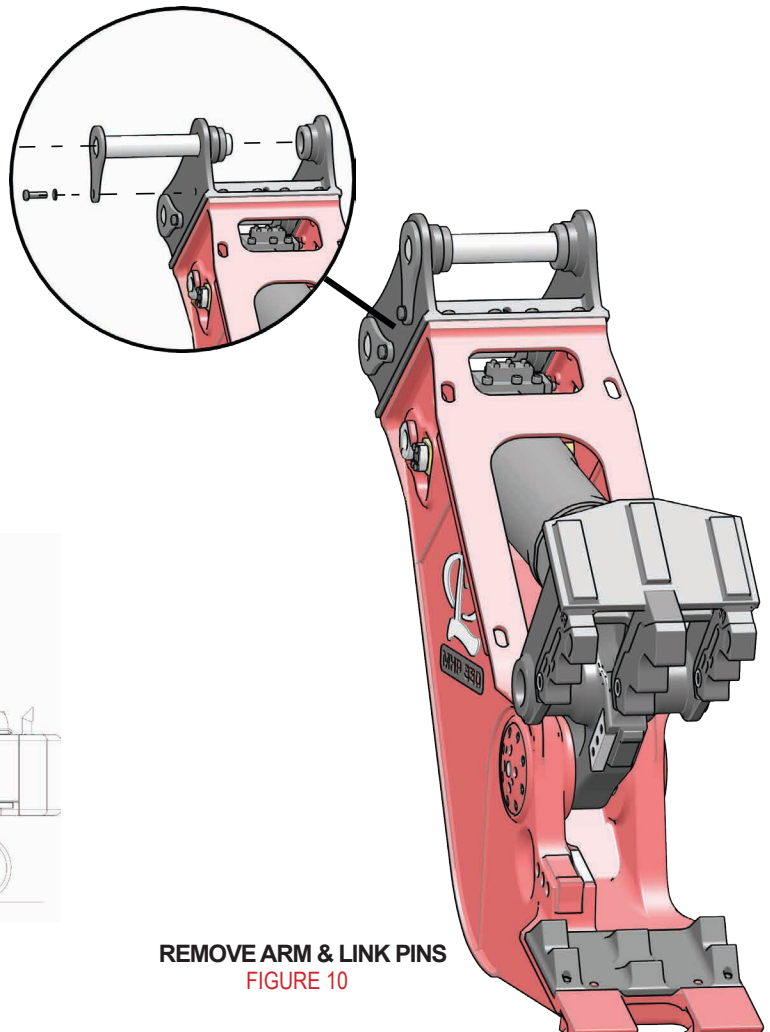

REMOVE ARM & LINK PINS
FIGURE 10

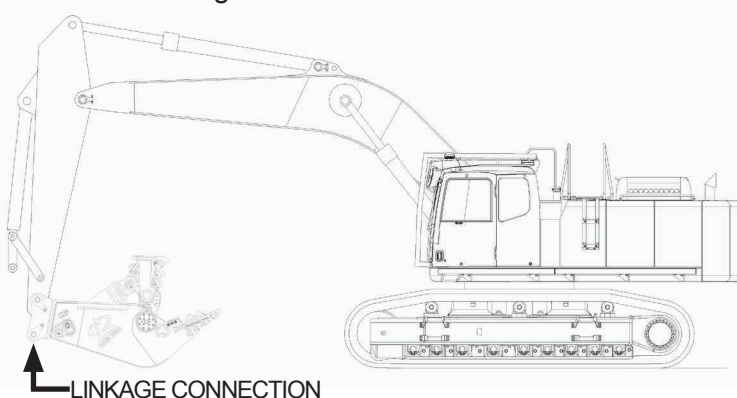

LINKAGE CONNECTION
THIRD MEMBER INSTALLATION
FIGURE 11

INSTALLATION

HYDRAULIC INSTALLATION

Read the hydraulic letter provided by LaBounty before the arrival of the attachment. This letter states the hydraulic requirements for the specific attachment. Also refer to “MHP Hydraulic Schematic” on page 23.

WARNING

- **DO NOT** install hydraulic lines while they are pressurized. Escaping fluid under pressure can penetrate the skin, causing serious injury.

Hydraulic Circuit Requirements

Model	Cylinder Circuit	Connection
MHP 200	40-65 GPM (150-250 LPM) 4500-5500 PSI (310-380 Bar)	1" Code 62 Flange
MHP 350	50-110 GPM (190-416 LPM) 4500-5500 PSI (310-380 Bar)	1" Code 62 Flange

1. Connect hydraulic hoses from the base machine to the connections on MHP (Figure 12).

Note: Remember to cap all hydraulic hoses and fittings immediately to prevent contamination of the oil.

2. Check for any hydraulic oil leaks or interference.

Note: Hydraulics will need to be bled before putting into service (see “Bleed the Hydraulic Cylinder” on page 15).

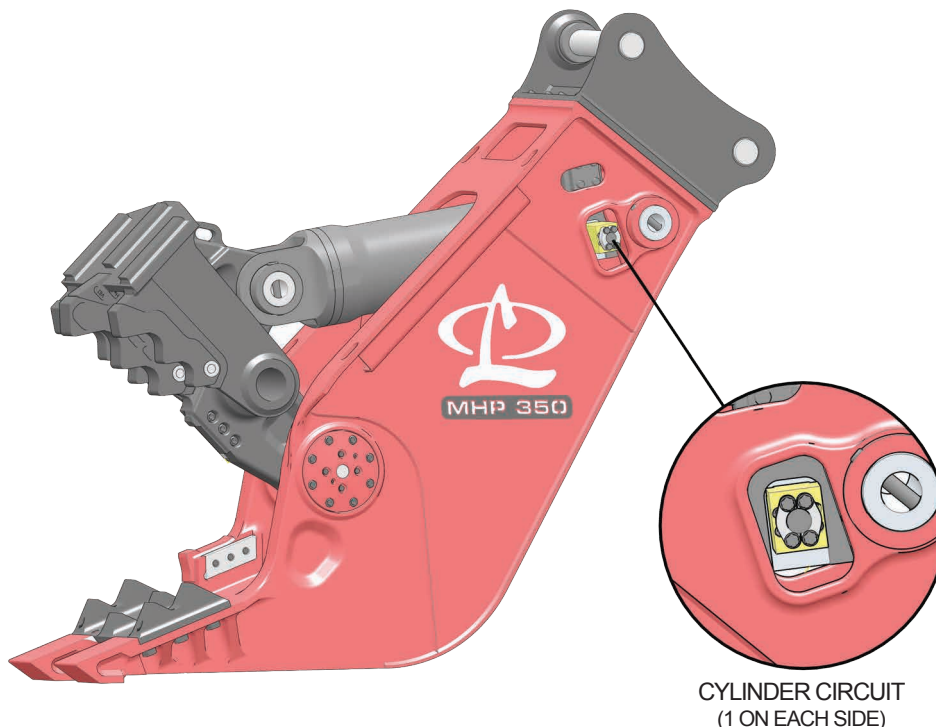

HYDRAULIC CONNECTIONS
FIGURE 12

OPERATION

BEFORE YOU START

Know Your Safety Program

- Read and understand this manual and the base machine manual.
- Know the employer's safety rules. Consult your foreman for instructions and safety equipment.
- Learn the traffic rules at the work site. Know the hand signals used on the job and who is responsible for signaling. Take signals from only **ONE** person.
- Wear personal protection equipment. This includes eye protection, hard hat, steel toe shoes, gloves, hearing protection and respirator.



Know Your Equipment

- Learn and test the function of all controls. If malfunctions are found, shut the machine down and report the malfunction for repair.
- Be familiar with safety devices, indicators, warning devices and caution instructions. They will alert you to conditions that are hazardous.
- Know the clearances in the work area.

Daily Safety Checks

- Ensure all decals are installed and legible. Contact LaBounty for replacements as required.
- Have a **DAILY** safety dialog with all workers. Inform them of any abnormal work that is planned. Remind them of the safe working distance.
- Clear the area. **ALWAYS** look out for others. In any work area, people constitute a serious safety hazard. Before operating, walk around the machine to ensure no workers are next to, under or on it. Warn nearby workers that you are starting up. **DO NOT** start up until they are out of danger.
- Check the location of cables, gas lines and water mains before operation. Ensure work site footing has sufficient strength to support the machine. When working close to an excavation, position machine with the propel motors at the rear.
- Keep bystanders clear, especially before moving the boom, swinging the upper structure, or traveling. **ALWAYS** be alert for bystanders in or near the operating area.

Safety Devices

- Seat belts
- Safety decals
- Flags and flares
- Signs and other markings
- Falling Objects Protective Structures (FOPS)
- Canopies
- Shields and guards
- Barricades
- Warning lights
- Visual or audible warning devices

General Rules For Safe Operation

- **KNOW** the capacity of the excavator and it's attachments. **DO NOT** overload or serious injury could result. The attachment may have altered the machine's lift capabilities.
- MHP is for processing materials. **DO NOT** use for unapproved purposes or warranty may be voided.
- If MHP stalls during processing, scale back the amount of material being processed at one time. Overloading can cause overheating and has adverse effects on the hydraulic system.
- Cycle the MHP cylinder completely when processing. Fully cycling MHP will allow hydraulic fluid to circulate and prevents overheating.
- Maintain a safe distance.
- **NEVER** leave MHP suspended or pass it over people, occupied vehicles or buildings.
- When working in confined spaces, keep watch on exposed parts, such as cylinder rods and hoses, to avoid damage.
- Maintain at least 15 feet (5 meters) between MHP and any nearby power lines.
- **ALWAYS** lower MHP to the ground and turn the base machine off when leaving the machine unattended.
- **DO NOT** close the jaws on a structure and reverse the excavator in an attempt to pull down material. This is dangerous and will damage the excavator and the MHP attachment.
- **DO NOT** alter factory preset hydraulics. This may void the warranty.
- **DO NOT** shear high tensile steel, such as railroad rail, spring steel, axles and some types of wire. Jaw damage will result. This type of material breaks when processed and can become a projectile which could cause injury or death.

OPERATION

TECHNICAL SPECIFICATIONS

Model	Weight	Jaw Opening	Jaw Depth	Lower Width	Reach	Max. Pressure	Max. Flow	Cycle Time (@ Max. Flow)	Minimum Excavator Size
MHP 200	4850 Lbs. (2200 Kg)	37 in (940 mm)	33 in (840 mm)	21 in (530 mm)	8.9 ft (2.7 m)	5500 PSI (380 Bar)	65 GPM (245 LPM)	4 sec.	44000 Lbs (20 M/Ton)
MHP 350	6650 Lbs. (3000 Kg)	44 in (1120 mm)	40 in (1020 mm)	24 in (610 mm)	9.5 ft (2.9 m)	5500 PSI (380 Bar)	110 GPM (415 LPM)	4 sec.	66000 Lbs (30 M/Ton)

ATTACHMENT CONTROLS

WARNING

- Learn the control for each movement of the attachment before attempting to operate.

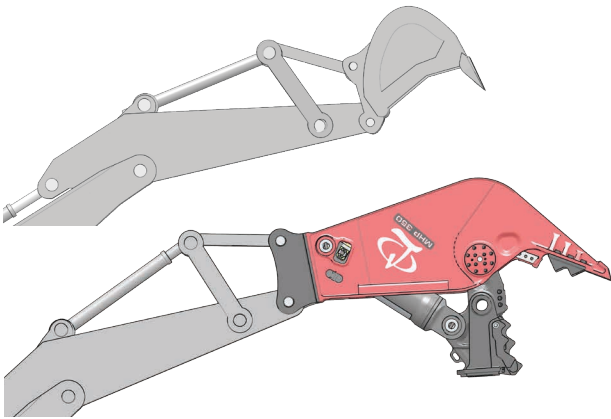

BUCKET DUMP → ATTACHMENT OUT
FIGURE 13

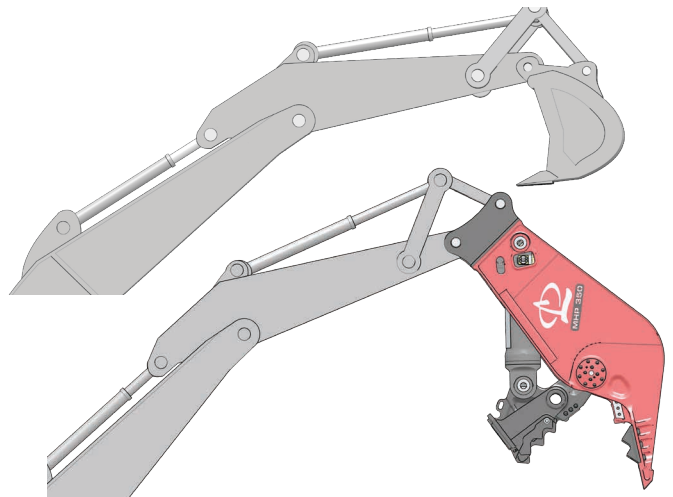

BUCKET CURL → ATTACHMENT IN
FIGURE 14

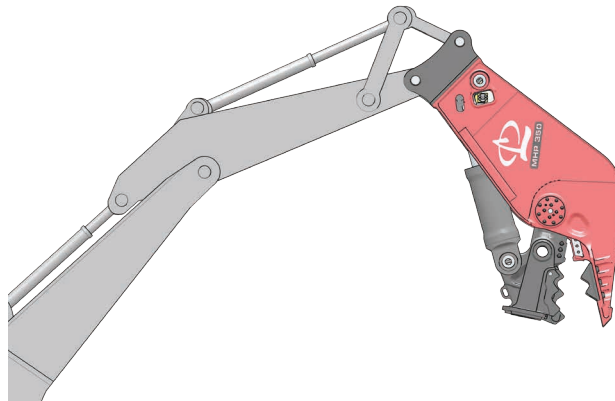

AUXILIARY SWITCH → JAWS CLOSE / OPEN
FIGURE 15

OPERATION

BLEED THE HYDRAULIC CYLINDER

Air must be bled out of the cylinder prior to operation. Air in the system leads to cavitation, oxidation of the oil and excessive heat. These conditions promote hydraulic oil break-down, contamination, noise, sluggish operation, reduced component life and potential cylinder damage.

1. Start with the attachment cylinder fully retracted. Shut off the excavator and operate the jaw controls in order to relieve any existing hydraulic pressure to the attachment cylinder.
 2. Set the excavator at idle speed.
 3. Slowly open the jaws until a noticeable change in tone of the excavator is heard, indicating a full cylinder. Release the controls and do not continue to apply full operating pressure to the cylinder.
 4. Slowly close the jaws until the cylinder rod is extended approximately 1/4 inch of stroke.
 5. Retract the cylinder rod all the way.
 6. Repeat steps 3 and 4. Extend the rod a quarter inch more each time, until you reach full stroke.
 7. Slowly cycle back and forth, at least five times, to full stroke. Be careful not to apply full operating pressure to the cylinder at this time.
 8. Check the base machine hydraulic fluid level and fill if necessary.
 9. Slowly extend and retract the excavator cylinder to it's limits. Check for interference between the attachment and the excavator boom or stick. Check the hydraulic lines that connect to the attachment . Ensure they are not rubbing or becoming damaged in any way. Contact your dealer immediately if interference occurs.
- When handling materials, keep the load as close to the base machine as safely possible. This will provide the greatest machine stability.
 - Avoid handling long, heavy materials off center.
 - When processing oversized concrete, make partial bites to start the breakage and then back off before making the next partial bite. This will allow the broken material to fall away between bites.
 - Sort your scrap to get the highest capacity from the attachment.
 - Understand that the attachment does have limits. Sometimes it may be necessary to downsize very large material by another method before the attachment can process it effectively.
 - Keep the attachment properly maintained. Jaws with excessive blade gaps or dull teeth are much less effective. Lack of maintenance can lead to greater problems and potential downtime.

OPERATING TIPS

- Start processing smaller materials and work up to larger materials. This will help you learn the limitations of the machine and will allow the machine to warm up properly.

MAINTENANCE

8-HOUR INSPECTION CHECKLIST

Inspect all safety devices

_____ Safety decals are in place and legible (see “Decals & Terms” on page 10)

_____ Cab protection is in good condition.

_____ Excavator warning systems are working.

Visually inspect for damage

_____ Check for physical damage to the attachment, jaws, hoses and fittings.

_____ Check for damage to the Swift-Lock Teeth (see “Swift-Lock Teeth Maintenance” on page 17).

Lubricate all points

_____ Lubricate attachment (see “Lubrication” on page 18).

Inspect bolts and hydraulic fittings

_____ Inspect bolts and fittings on attachment and jaws (see “Inspect / Torque Bolts” on page 19).

Inspect connecting pins and retaining hardware

_____ Arm Connection.

_____ Link connection.

_____ Front and rear cylinder pins.

_____ Main pivot group pin.

Inspect pivot group & jaw blades

_____ Check main pivot group for play (see “Main Pivot Group Maintenance” on page 19).

_____ Inspect blade gap & shear jaw guide blade gap (see “Blade Maintenance” on page 20).

80-HOUR INSPECTION CHECKLIST

Build-up, hard-surfacing & Blade Rotation

_____ Build-up jaws & check wear plates (see “MHP Hydraulic Schematic” on page 23).

_____ Rotate blades (see “Blade Maintenance” on page 20).

Inspected By: _____ Date: _____

MAINTENANCE

SWIFT-LOCK TEETH MAINTENANCE

When the jaw teeth are worn or cracking, performance is decreased and the teeth need to be replaced.

CAUTION

- Wear personal protection equipment at all times. This includes eye protection, hard hat, steel toe shoes, leather gloves and hearing protection.

Removing the Upper Teeth

1. Locate flat, hard ground and place the attachment on the ground.
2. Remove the washers, on each sides of each tooth, using a grinder.

Note: The washers are welded into place.

3. Use a soft metal drift and a mallet to drive out the tooth pin.
4. Remove the tooth from the receptacle.

Note: The retainer ring may fall out when removing the teeth. Do not lose the retainer ring.

5. Insert the retainer ring in its place and insert a new Swift-Lock tooth.
6. Insert the tooth pin and weld the washers in place.

Note: Insert the tooth pin so that the pin groove will line up and seat in the retainer ring.

WARNING

- Swift-Lock Teeth are very heavy. **DO NOT** remove a tooth pin if the tooth is not supported. The tooth may fall and cause injury.

Removing the Lower Tooth Platen

1. Remove (6) M30 capscrews from the bottom of the lower jaw. Do not reuse the capscrews.
2. Remove the Lower Tooth Platen.
Note: There are 3 dowel pins press fit into the Lower Tooth Platen for positioning. Insert new dowels into the new Lower Tooth Platen.
3. Install a new Lower Tooth Platen. Apply Loctite 262 to the installation bolts and torque to 1350 ft/lbs. (1850 Nm).

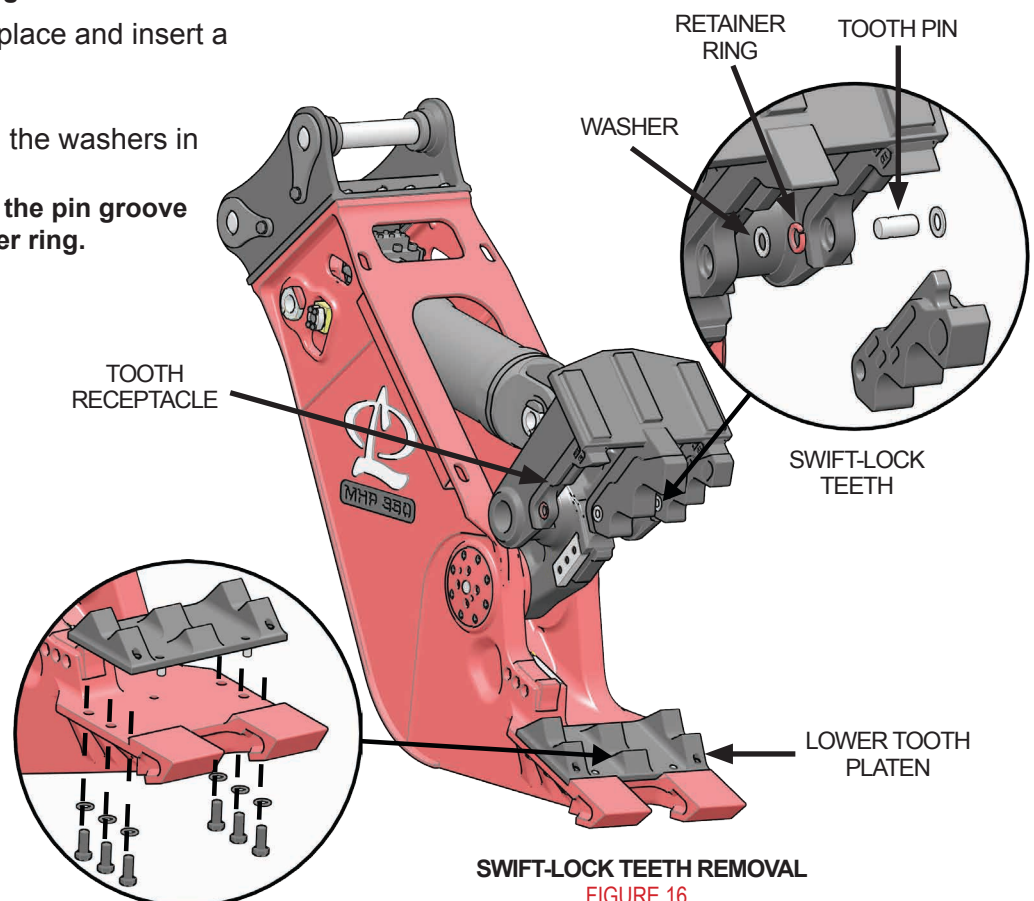

SWIFT-LOCK TEETH REMOVAL
FIGURE 16

MAINTENANCE

LUBRICATION

Use premium grease, No. 2EP. Grease fittings are indicated on the attachment by yellow "GREASE" decals. Each grease fitting requires .3 oz (8 g) of grease. This is about 6 shots of grease from an average grease gun.

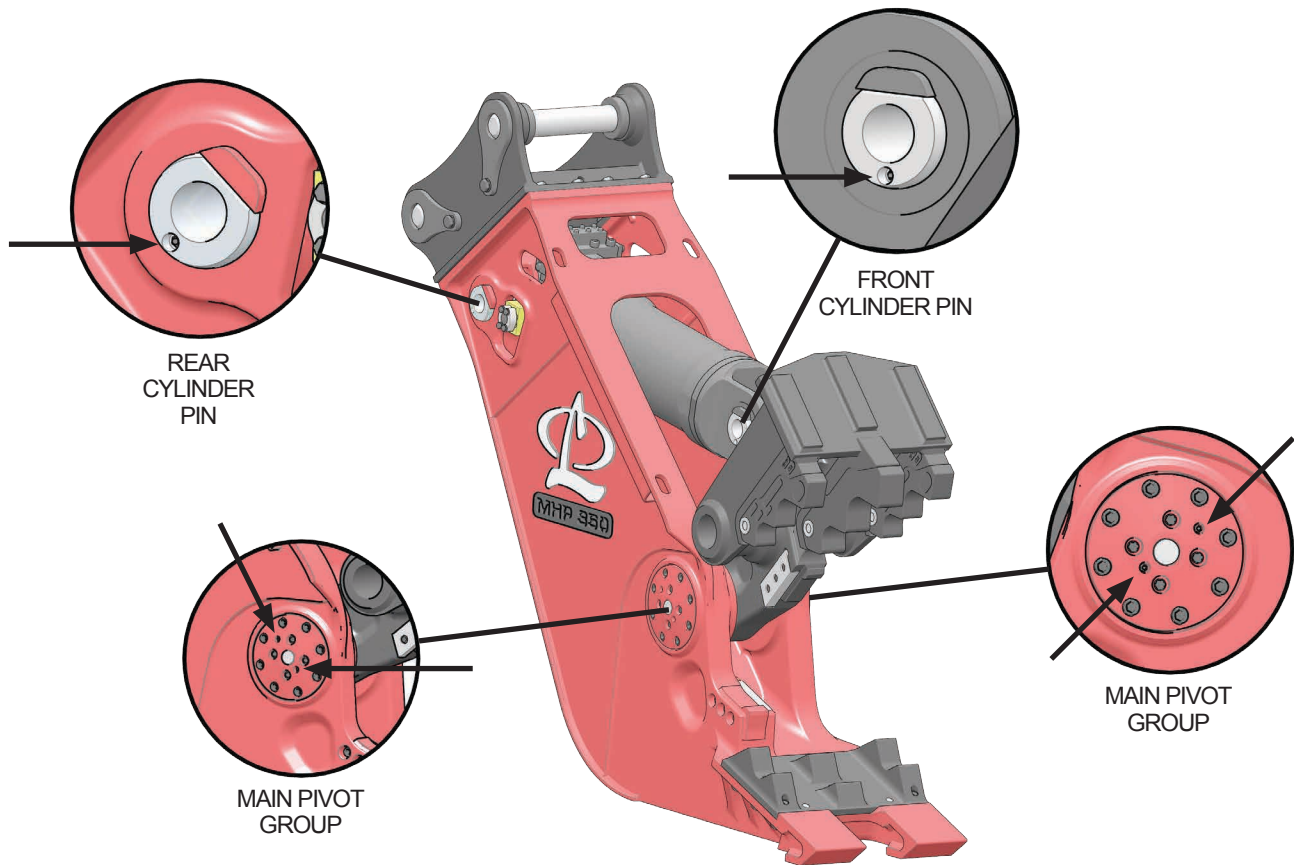

MHP LUBRICATION POINTS

FIGURE 17

MAINTENANCE

INSPECT / TORQUE BOLTS

Inspect all bolts for damage. Check the torque of all bolts and replace any bolt that is damaged or has been re-torqued more than once. Always use replacement bolts of the same size and class as the one removed. Unless otherwise specified, use class 10.9 metric hex head capscrews, class 10.9 metric flat head capscrews and class 12.9 metric socket head capscrews. When installing new bolts, ensure that the bolt is clean and dry.

Note: Some bolts have unique torque specifications. Refer to the parts manual.



- **Never use an inferior class fastener. Fastener failure can cause damage, injury or death.**

Size	Torque	
	Class 10.9	Class 12.9
M10	41 ft/lbs (55 Nm)	49 ft/lbs (67 Nm)
M12	71 ft/lbs (96 Nm)	85 ft/lbs (116 Nm)
M14	112 ft/lbs (152 Nm)	136 ft/lbs (185 Nm)
M16	173 ft/lbs (235 Nm)	207 ft/lbs (281 Nm)
M20	335 ft/lbs (454 Nm)	403 ft/lbs (547 Nm)
M24	579 ft/lbs (785 Nm)	693 ft/lbs (939 Nm)
M30	1164 ft/lbs (1579 Nm)	1391 ft/lbs (1887 Nm)

GENERAL FASTENER TORQUE

FIGURE 18

Flange	Flange Code	Bolt Size	Torque
1.00"	61	M10 x 1.50	42 ft/lbs (57 Nm)
1.00"	62	M12 x 1.75	70 ft/lbs (95 Nm)

HYDRAULIC FLANGE FASTENER TORQUE

FIGURE 19

MAIN PIVOT GROUP MAINTENANCE

Check for play in the main pivot group **BEFORE** performing maintenance on rebar blades.

1. Fully open the jaws.
2. Lower MHP so the lower jaw is on the ground. Turn off the base machine.
3. Using a pry-bar between the upper and lower jaw (Figure 20), attempt to move the jaws.
4. Measure the movement using a dial indicator. If movement is visible, contact your LaBounty Dealer or LaBounty Customer Service.

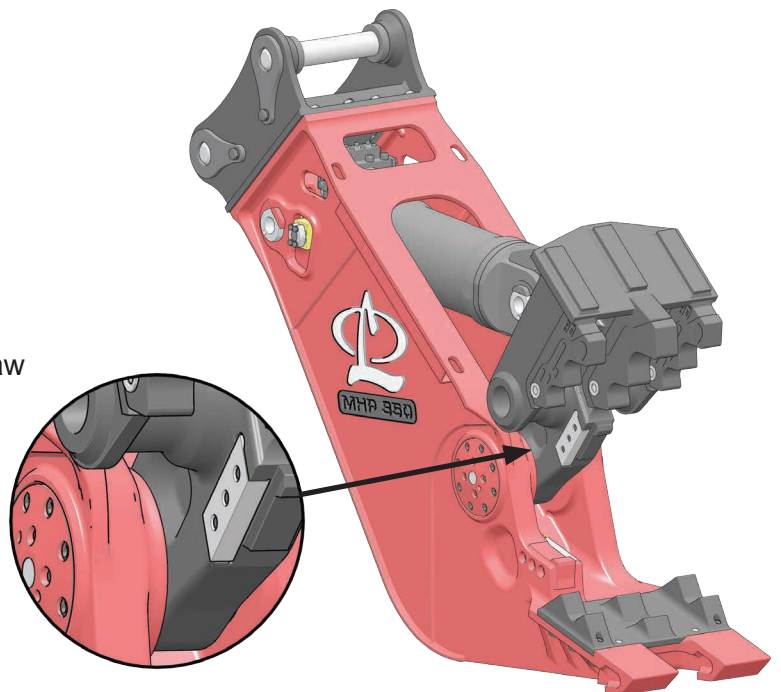

MAIN PIVOT GROUP PRY-BAR LOCATION

FIGURE 20

MAINTENANCE

BLADE MAINTENANCE

CAUTION

- Wear leather work gloves at all times during blade maintenance.

1. Remove the blade as shown in Figure 21.
2. Grind all rough edges from each blade and clean the blade seat.
3. Rotate the blade.
Note: Each blade has four edges, as shown in Figure 22 & Figure 23. Each time you rotate the blade, you use a different edge. Replace blades when all edges are rounded to .25" radius.
4. Reinstall each blade using 500 Ft/Lbs (680 N/M) torque on each bolt.

DANGER

- Stay at least 75 ft. (23 m) when moving.
5. Cycle the jaws closed. Measure the gap between the upper and lower blade using a feeler gauge. If the gap is larger than .030", shim the blade.

Shimming the Blades

1. Measure the blade gap.
2. Shim each blade so that the blade gap is approximately .020" - .030". Fit the shims between the blade and the blade seat.

Note: Do not shim out a blade more than .125". Doing so may cause structural damage and will void the warranty.

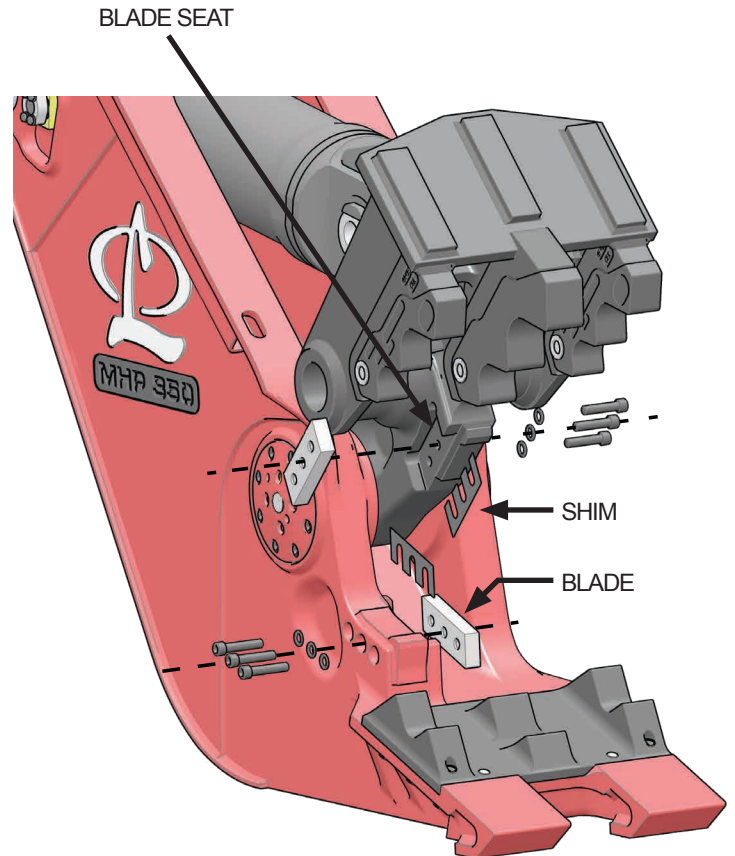

BLADE & SHIM EXPLODED VIEW

FIGURE 21

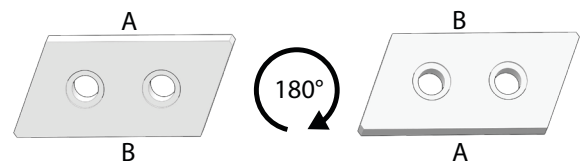

BLADE PITCH ROTATION

FIGURE 22

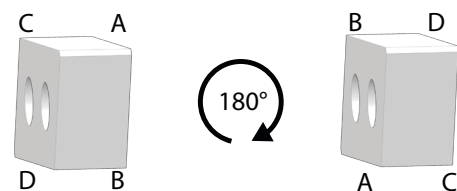

BLADE ROLL ROTATION

FIGURE 23

MAINTENANCE

BUILD UP & WEAR PLATES

As the jaws become worn from use, the worn areas will need to be built up to prolong the life of the attachment. Some areas of the jaw have wear plates that protect commonly worn surfaces and reduces the need to build up and hard-surface.

⚠ CAUTION

- **Wear safety equipment when welding. This includes eye protection, hard hat, steel toe shoes, gloves, hearing protection and respirator.**
- **Do all work in a well ventilated area.**

CHECKING AND REPLACING WEAR PLATES

Wear bars are welded into the jaw and must be replaced after they have worn down to 1/4 their original thickness.

Using the MHP parts manual, ensure you have ordered the proper wear plate kits.

Installing Wear Bars

1. Preheat the area around the wear bar to 250° to 300° F.
2. Remove the worn wear bar.
3. Fit the new wear bar into the receptacle.
Note: Wear bars are pre-cut to length and must be formed to the jaw in the field.
4. Weld the wear bar into place.
5. Cover the weld with a heat blanket and allow it to cool slowly.

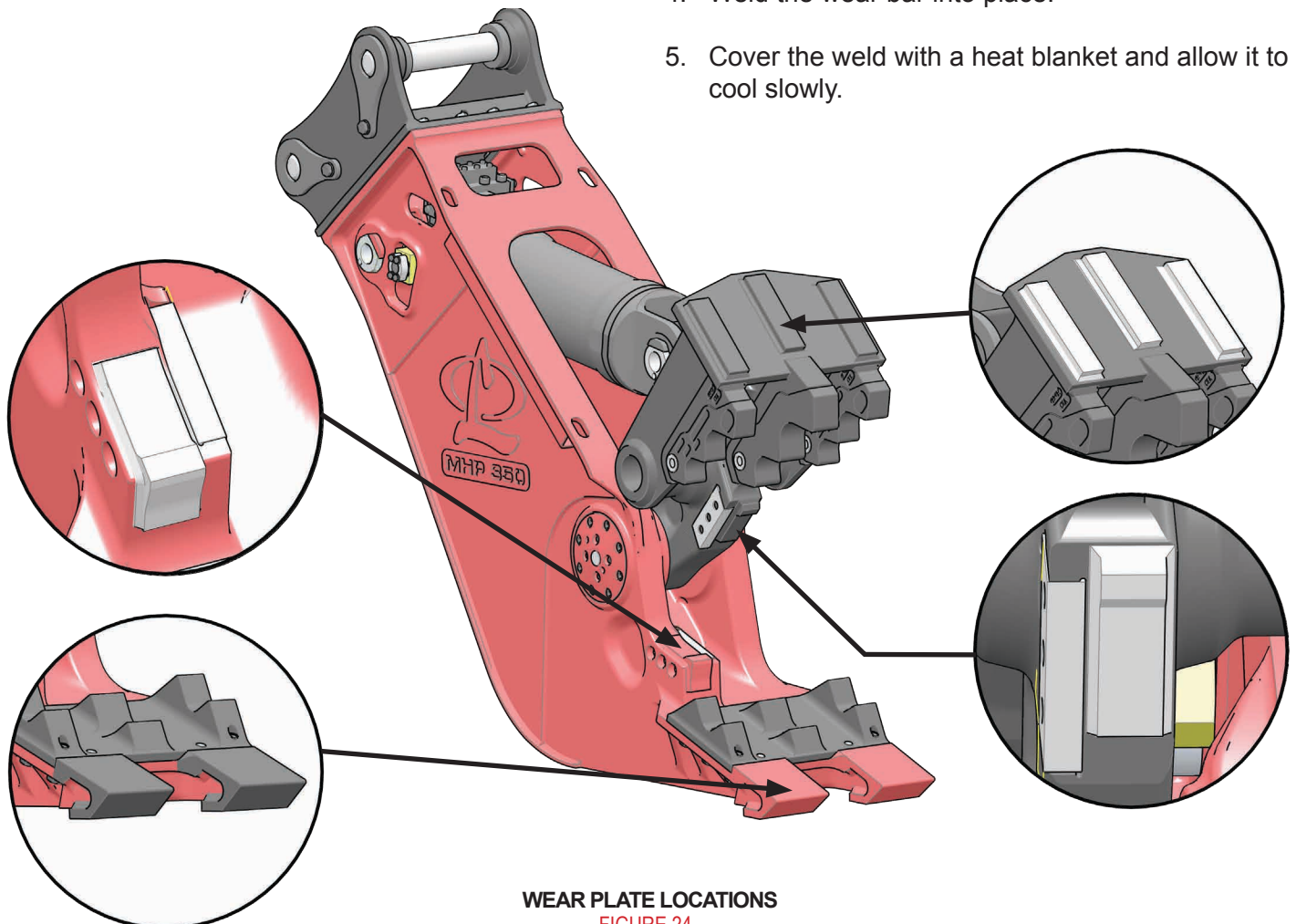

WEAR PLATE LOCATIONS

FIGURE 24

MAINTENANCE

SWIFT-LOCK TEETH / LOWER TOOTH PLATEN BUILD UP

1. Obtain the proper Swift-Lock tooth template. Refer to the parts manual for template part numbers.
2. Thoroughly clean the area to be build up. Grind off any existing hard-surface material.
3. Preheat the area to 200° F (93.3° C) to remove moisture.
4. Preheat the area to be build up to 300° - 400° F (149° - 204° C)
Note: Do not exceed 450° F (232° C).
5. Use the tooth template to determine how much buildup is required.
6. Using AWS E7018 welding rod, make hard surface beads, as shown in Figure 25.
7. Relieve stress and remove slag after each pass by peening vigorously with an air operated slag peener.
8. Repeat steps 6 and 7 until the tooth profile matches the build up template.
9. Grind edges square to match the template.
10. Using AWS E7018, place underlayment passes, as shown in Figure 25.
11. Apply a bead of Amalloy 814H rod on top of each of the underlayment beads.
Note: Do NOT apply Amalloy 814H to the base metal.
12. Relieve stress after each pass by peening vigorously with an air operated slag peener.
13. Taper the end of each hard-surface bead by grinding.
Note: Do NOT undercut the weld.
14. When grinding is complete, peen the area until it is shiny or until the peener cannot dent the weld.
Note: About 5-10 minutes.
15. Cover the welded area with a heat blanket and allow to cool slowly.

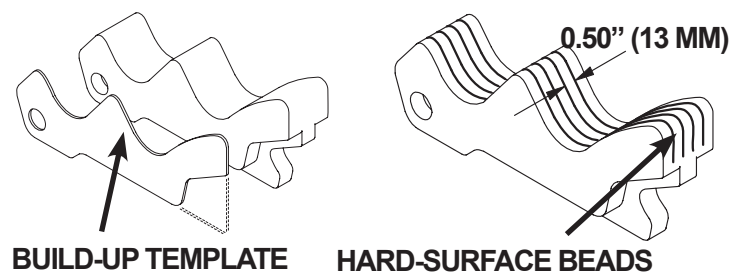

SWIFT-LOCK TOOTH & LOWER TOOTH PLATEN BUILD-UP

FIGURE 25

MAINTENANCE

HYDRAULIC MAINTENANCE

Speed Valve

The speed valve allows the jaws to shift into high speed when not under a load. Two valve spools control this speed change, the Main Spool Adjustment Screw and the Pilot Valve Adjustment Screw.

Testing the Speed Valve

Close the jaws and observe the movement. If the speed valve is working properly, the jaw closing speed will increase after 1-2 inches of movement. Next, open the jaws and observe the movement. Once again, the jaw speed will increase after 1-2 inches of movement.

Adjusting the Speed Valve

- If the jaw movement doesn't shift to high speed when **CLOSING**, adjust the pilot valve adjustment screw clockwise until the jaws shift speed.
- If the jaw movement doesn't shift to high speed when **OPENING**, adjust the main spool adjustment screw clockwise until the jaws shift speed.

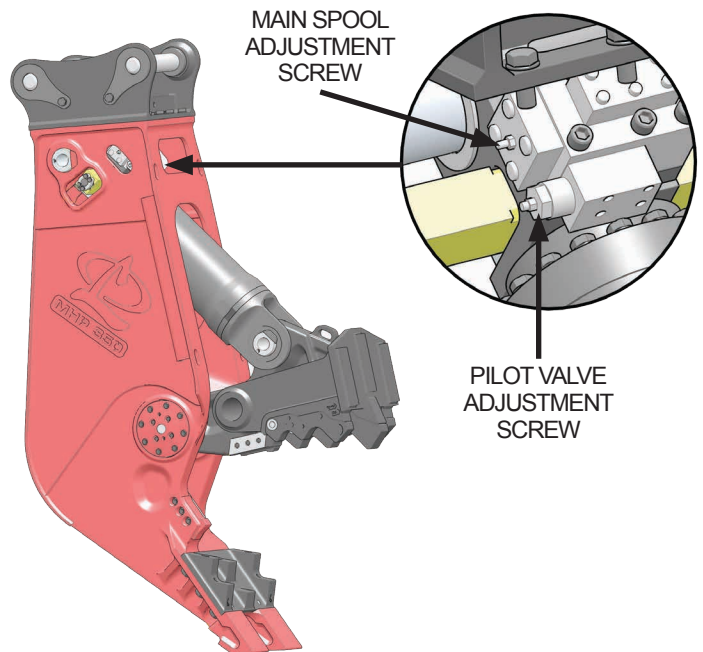

SPEED VALVE ADJUSTMENT POINTS

FIGURE 26

MHP HYDRAULIC SCHEMATIC

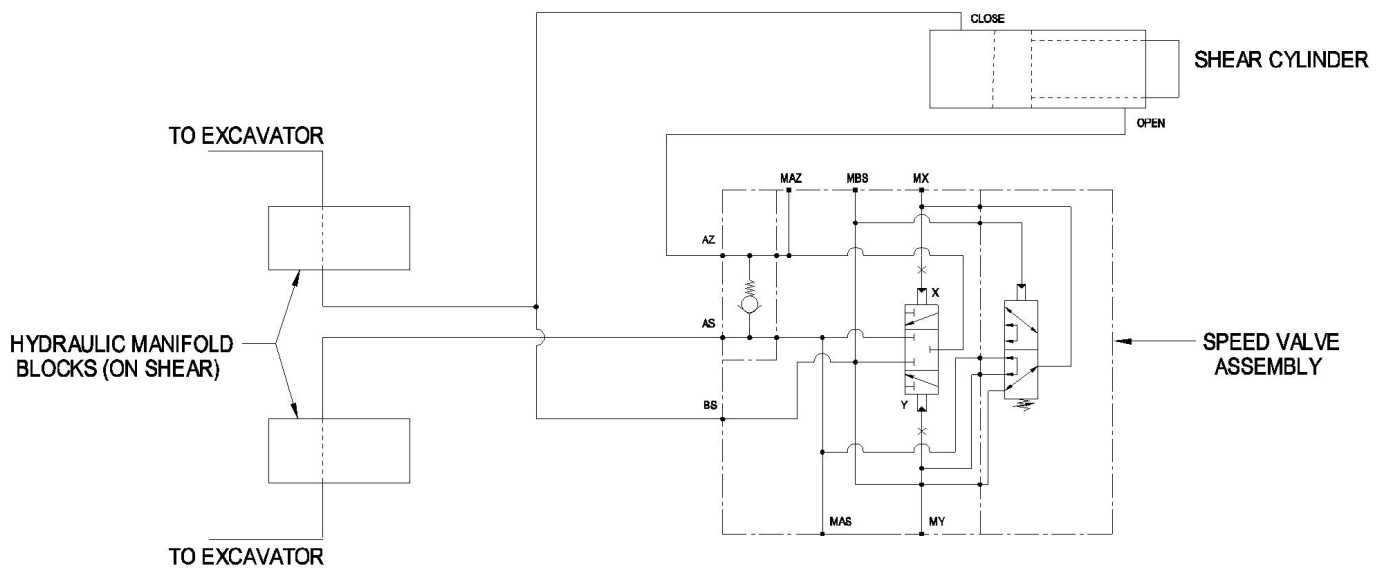

TROUBLESHOOTING

FIRST STEPS

- Ensure the hydraulic flow and pressure from the base machine meets specifications (see “Hydraulic Circuit Requirements” on page 12).
- Inspect all hydraulic lines for kinks or damage. Replace any damaged hydraulic lines.

SYMPTOM	CAUSE	REMEDY
MHP jaws will not move, move too fast or move too slow.	Check speed valve operation	Adjust if necessary (see “Adjusting the Speed Valve” on page 23)
MHP cannot process or hold material in the jaws.	The material is too big.	Consult the factory.
	Speed valve needs adjustment.	See “Adjusting the Speed Valve” on page 23.
	Back pressure is too high.	Check all hydraulic lines and ensure they are not kinked and are of the proper size. Check the base machine circuit for restrictor valves.
The jaws don’t shift speed when closing.	Pilot valve pressure is too high.	Adjust the pilot valve adjustment counter clockwise in small increments until issue is corrected (see “Adjusting the Speed Valve” on page 23).
Jaw speed wont shift when the jaws are partially opened.	Back pressure is too high in the base machine return line.	Use larger diameter hydraulic lines to minimize back pressure. Move the main spool adjustment screw clockwise in small increments until the issue is corrected (see “Adjusting the Speed Valve” on page 23).
Jaws continue to close after the operator has let go of the controls, after moving in speed mode.	The main valve spool isn’t fully shifting out of speed mode.	Move the main spool adjustment screw clockwise, in small increments, until the issue is corrected (see “Adjusting the Speed Valve” on page 23).
The jaws lack power.	The main valve spool isn’t fully shifting out of speed mode.	Move the main spool adjustment screw counter clockwise, in small increments, until the issue is corrected (see “Adjusting the Speed Valve” on page 23).



LaBounty
1538 Highway 2
Two Harbors, Minnesota 55616-8015
USA
Phone: (218) 834-2123
Fax: (218) 834-3879

Additional copies of this manual are available by contacting your dealer or the LaBounty parts department, and requesting a CE Operation & Maintenance manual. You must include the attachment model number and serial number.